

SPEC SHEET (FOR REFERENCE)	SHEET No.	G05022A	Page.
			1 of 1

TYPE : 6PT1606N1T**

CHIP SIZE	0.36 * 0.36 mm
WAFER SIZE	6 inch
POSSIBLE DIE PER WAFER	119,000 pcs

Maximum Ratings(Ta=25°C)

Characteristics	Symbol	Ratings	Unit
Drain-source voltage	VDSS	50	V
Gate-source voltage	VGSS	±8	V
Drain Current (DC)	ID	0.15	A

* For Reference

PROBING SPEC (Ta=25°C)

No	MODE	LIMIT				CONDITIONS
		MIN.	Typ	MAX.	UNIT	
1	IGSS			±1	uA	VGS= ±8V VDS= 0V
2	IDSS			10	uA	VDS= 52V VGS= 0V
3	BVDSS	52			V	ID= 100uA
4	VTH	0.65		1.05	V	ID= 250uA
5	RDS(on)		3.5	5.0	Ω	VGS= 4.0V ID= 100mA
6	Yfs	180			mS	VDS= 10V Id= 100mA

※ Built-in ZD between Gate and Source.

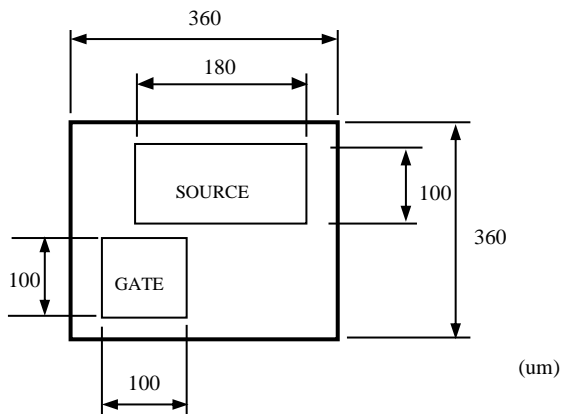

NOTE: