

SPEC SHEET (FOR REFERENCE)	SHEET No.	G05012A	Page.
			1 of 1

TYPE : 6PT1202N1T

CHIP SIZE	0.85 * 0.65 mm
WAFER SIZE	6 inch
POSSIBLE DIE PER WAFER	28,000 pcs

Maximum Ratings(Ta=25°C)

Characteristics	Symbol	Ratings	Unit
Drain-source voltage	VDSS	20	V
Gate-source voltage	VGSS	±8	V
Drain Current (DC)	ID	2	A

* For Reference

WAFER PROBING SPEC (Ta=25°C)

No	MODE	LIMIT				CONDITIONS
		MIN.	Typ	MAX.	UNIT	
1	IGSS			±1	uA	VGS=±8V VDS=0V
2	IDSS			500	nA	VDS=20V VGS=0V
3	BVDSS	23			V	ID=100uA
4	VTH	0.53		1.0	V	ID=1mA VDS=10V
5	RDS(on)1		75	105	mΩ	ID=0.5A VGS=4.5V
6	RDS(on)2		100	140	mΩ	ID=0.5A VGS=2.5V
7	RDS(on)3		170	230	mΩ	ID=0.1A VGS=1.8V
8	VSD		0.8	1.1	V	I=1.0A VGS=0V
9	Yfs		5		S	Vds=10V Id=0.5A

※ Built-in ZD between Gate and Source.

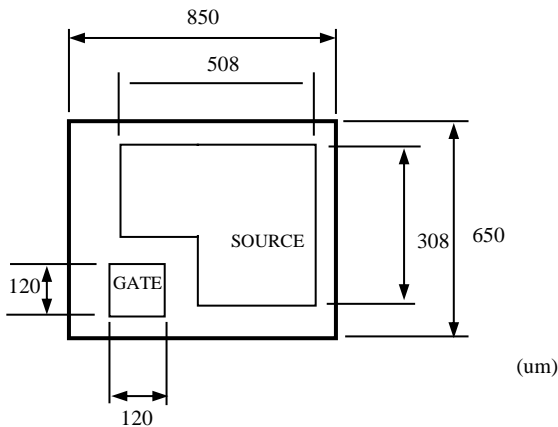

TENTATIVE

NOTE: